

24 Pin QFP Package Information

The package is a 24 lead metallized ceramic base glass sidewall Quad Flat Pack (QFP). The thermal

impedance (junction to base) is approximately 25 °C/W. The lid is sealed with epoxy.

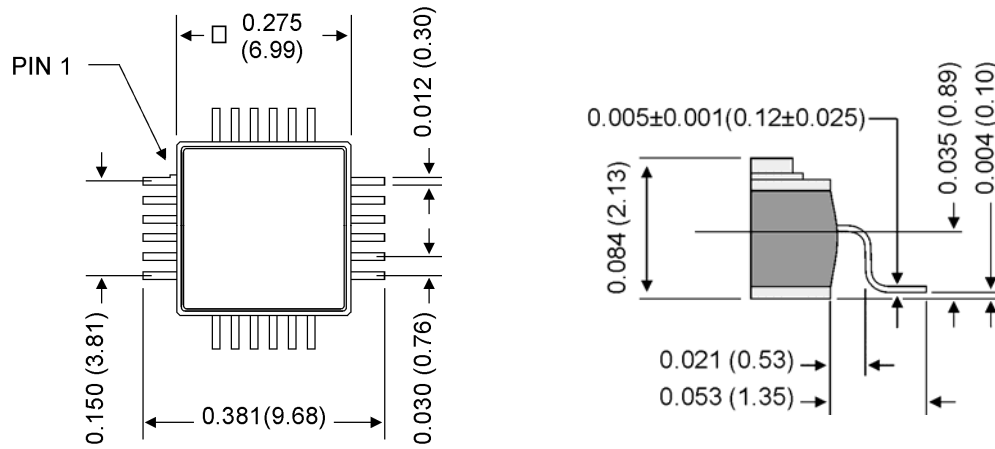

Figure 1. Package outline, dimensions in inches (mm), tolerance $\pm 0.002''$ ($\pm 0.051\text{mm}$).

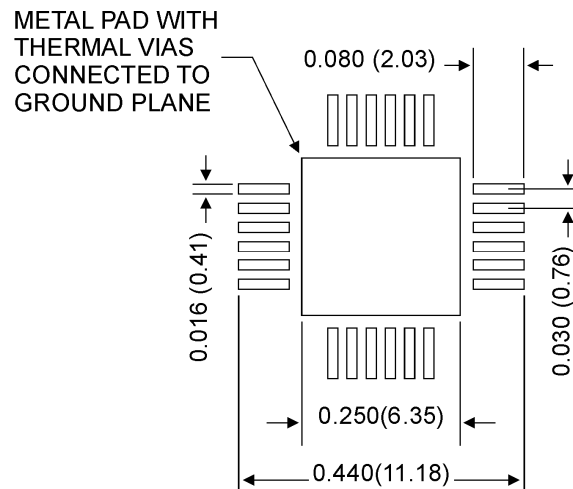

Figure 2. Footprint dimensions shown in inches (mm).